

DH-IPC-HF5221E

2MP Full HD WDR Network Camera



Features

- 1/2.7" 2Megapixel progressive scan CMOS
- Support H.264,MJPEG dual codec
- Max 25/30ps@2M(1920x1080)
- WDR up to 120dB
- Ultra 3D DNR, Excellent performance under low illumination
- Smart detection
- Auto back focus(ABF)
- Micro SD memory, PoE

DH-IPC-HF5221E

Technical Specifications

Model	DH-IPC-HF5221E	
Camera		
Image Sensor	1/2.7" 2Megapixel progressive scan CMOS	
Effective Pixels	1920(H)x1080(V)	
Scanning System	Progressive	
Electronic Shutter Speed	Auto/Manual, 1/3(4)~1/10000s	
Min. Illumination	0.02Lux/F2.0(Color), 0.02Lux/F2.0(B/W)	
S/N Ratio	More than 50dB	
Video Output	1 channel BNC (1.0Vp-p, 75Ω)	
Camera Features		
Max. IR LEDs Length	N/A	
Day/Night	Auto(ICR)/Color/B/W	
Backlight Compensation	BLC / HLC / WDR(120dB)	
White Balance	Auto/Manual	
Gain Control	Auto/Manual	
Noise Reduction	3D	
Privacy Masking	Up to 4 areas	
Ultra Defog	Support	
Smart focus	ABF	
Lens		
Mount Type	C/CS	
Video		
Compression	H.264/H.264B/H.264H/ MJPEG	
Resolution	1080P(1920×1080)/720P(1280×720)/D1(704×576)/CIF(352×288)	
Frame Rate	Main Stream	1080P/720P(1 ~ 25/30fps)
	Sub Stream	D1/CIF(1 ~ 25/30fps)
	Third Stream	720P(1-13/4fps)
Bit Rate	H.264: 32Kbps ~ 10Mbps	
ROI	Up to 4 areas	
Audio		
Compression	G.711a / G.711u/AAC	
Interface	1/1 channel In/Out	
Smart Function		
Smart detection	Tripwire	
	Intrusion	
	Scene change	
	Face detect	
Network		
Ethernet	RJ-45 (10/100Base-T)	
Wi-Fi	N/A	
Protocol	IPv4/IPv6, HTTP, HTTPS, SSL, TCP/IP, UDP, UPnP, ICMP, IGMP, SNMP,	

DH-IPC-HF5221E

	RTSP, RTP, SMTP, NTP, DHCP, DNS, PPPOE, DDNS, FTP, IP Filter, QoS, Bonjour
Compatibility	ONVIF ,PSIA,CGI
Max. User Access	20 users
Smart Phone	iPhone, iPad, Android, Windows Phone
Auxiliary Interface	
Memory Slot	Micro SD, Max 128GB
RS485	1
Alarm	1/1 channel In/Out
General	
Power Supply	DC12V/AC24V, PoE (802.3af)
Power Consumption	Max 10W (ABF&ICR on)
Working Environment	-40°C~+60°C, Less than 95% RH
Ingress Protection	N/A
Dimensions	74.1mm×65.5mm×135.4mm
Weight	0.3Kg

DH-IPC-HF5221E

Dimensions (mm)

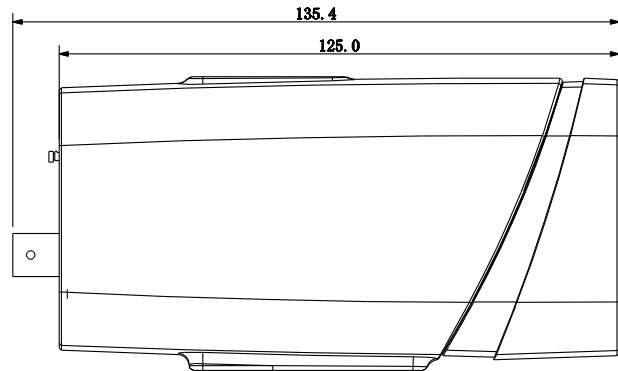
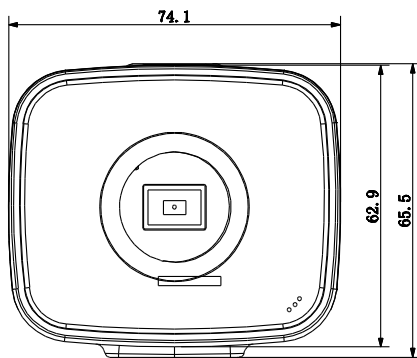

Accessory (optional)



Dahua Technology Co., Ltd.

1199 BinAn Road, Binjiang District, Hangzhou, China

Tel: +86-571-87688883

Fax: +86-571-87688815

Email: overseas@dahuatech.com

www.dahuasecurity.com

*Design and specifications are subject to change without notice.

© 2015 Dahua Technology Co., Ltd.